



BODYX MACH M9 ALL-IN-1 MACHINE

SKU: BODYX-M9







PRODUCT
DESCRIPTION

Bodyx Mach M9

Convenient and space saving with using pin select weight stacks for smith bar weight

Remove the need for traditional weight plate sleeves for smith machine, saving extra space for the width required

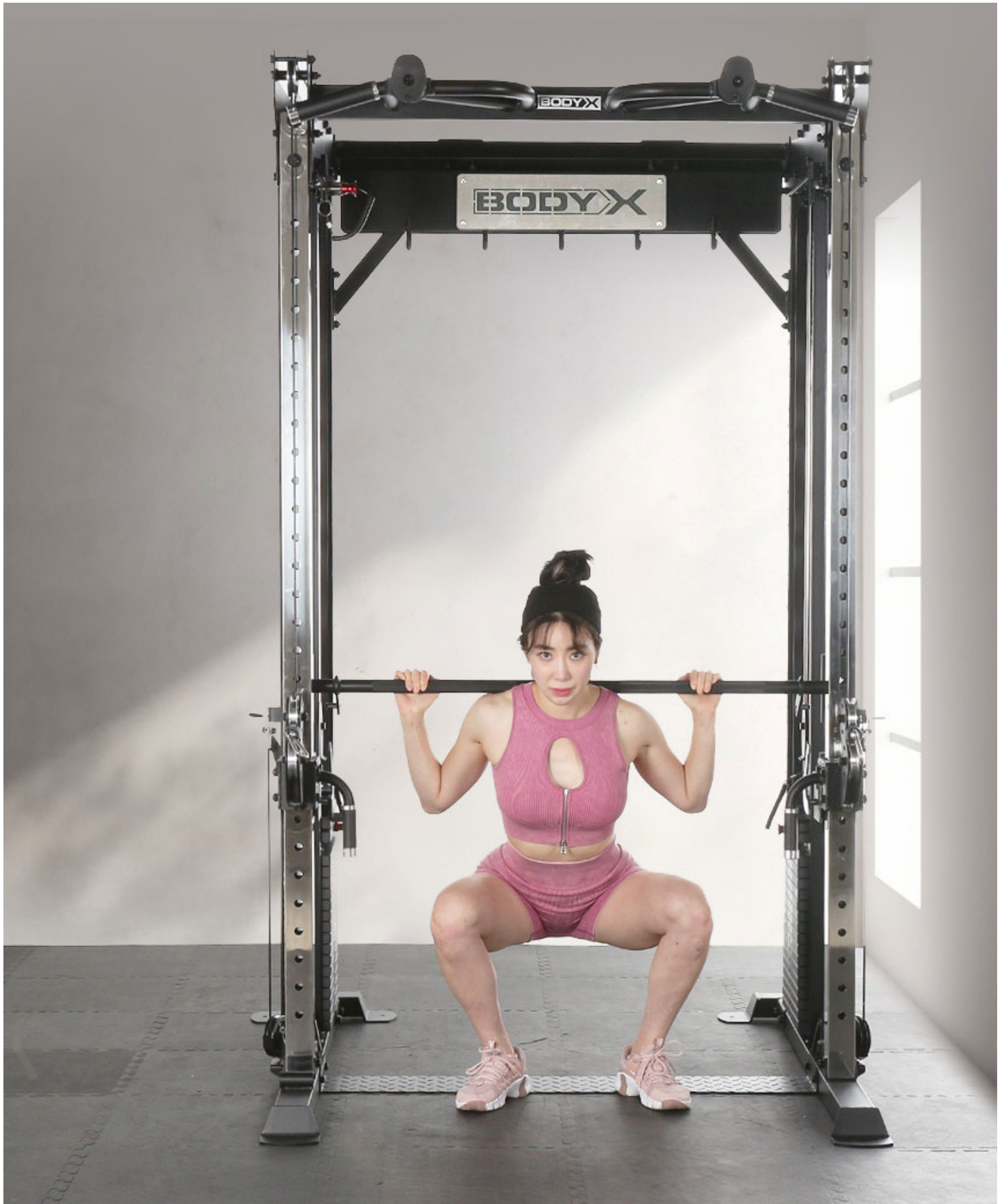

Ultra Smooth cable movement for functional trainer



Multi grip chin up bar with rock climbing handle to suit different needs

Slanting dips handle to cater to different width

INCLUDED ACCESSORIES



1) Bench pad with knee holder for lat pulldown



2) Leg plate for low row

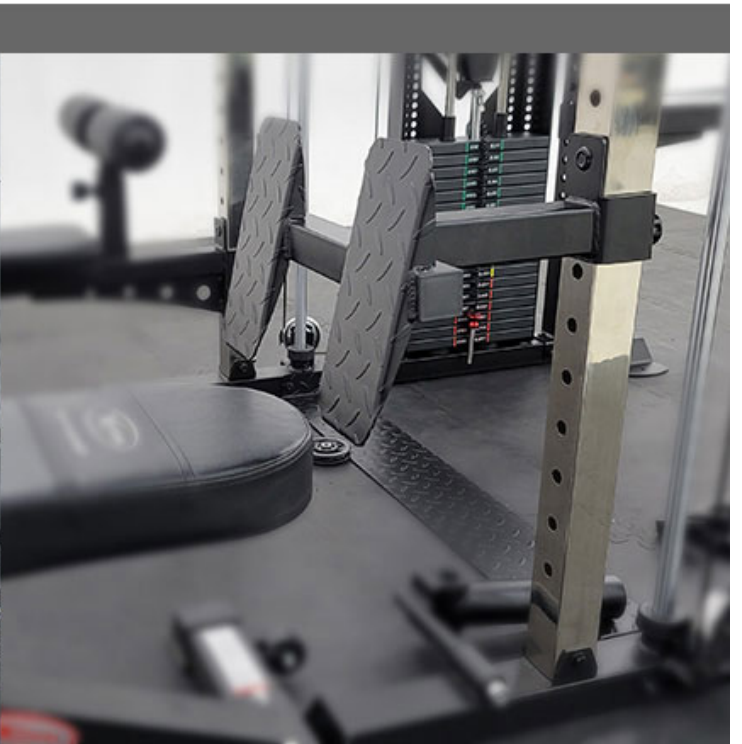
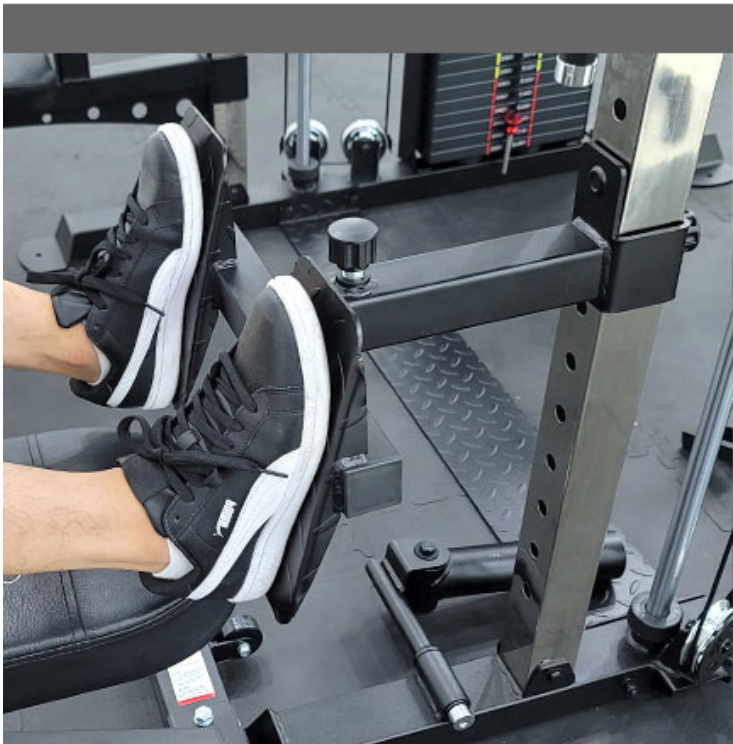
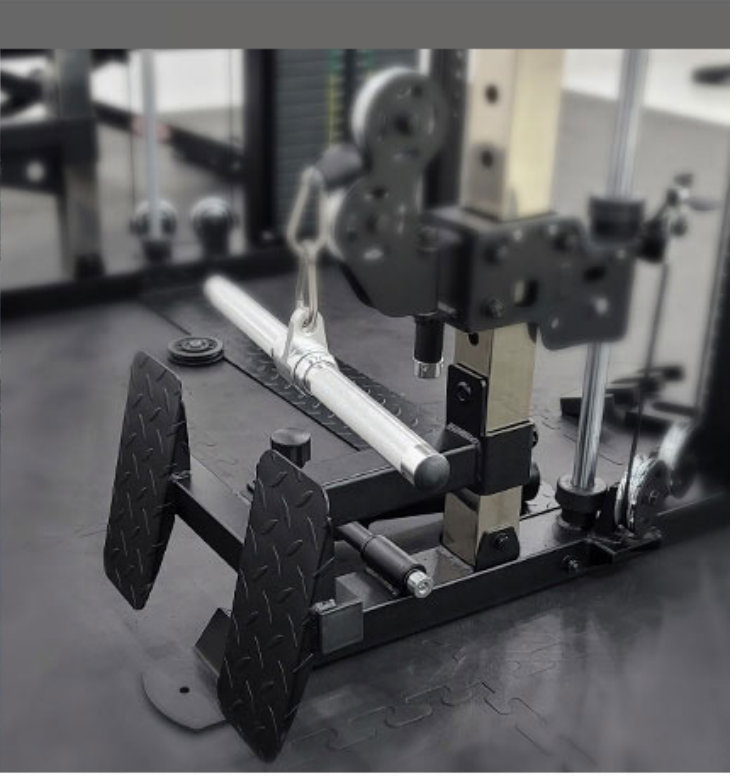
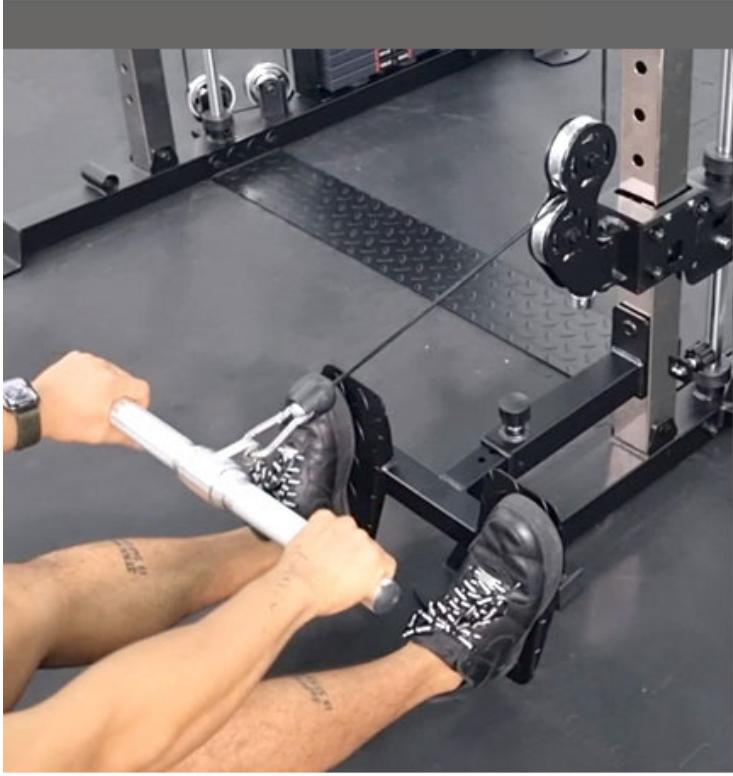

Switchable to knee holder attachment to do lat pulldown with a bench



Smith Bar goes low enough for deadlift

Additional 1kg and 2kg weights provided to further finetune to your required weight



1KG BLOCK WEIGHT	BASE WEIGHT	ADD 1KG WEIGHT	ADD 2KG WEIGHT	ADD 3KG WEIGHT
	1 SIDE / 2 SIDES	1 SIDE / 2 SIDES	1 SIDE / 2 SIDES	1 SIDE / 2 SIDES
	5KG / 10KG	6KG / 12KG	7KG / 14KG	8KG / 16KG
	10KG / 20KG	11KG / 22KG	12KG / 24KG	13KG / 26KG
	15KG / 30KG	16KG / 32KG	17KG / 34KG	18KG / 36KG
	20KG / 40KG	21KG / 42KG	22KG / 44KG	23KG / 46KG
	25KG / 50KG	26KG / 52KG	27KG / 54KG	28KG / 56KG
	30KG / 60KG	31KG / 62KG	32KG / 64KG	33KG / 66KG
	35KG / 70KG	36KG / 72KG	37KG / 74KG	38KG / 76KG
	40KG / 80KG	41KG / 82KG	42KG / 84KG	43KG / 86KG
	45KG / 90KG	46KG / 92KG	47KG / 94KG	48KG / 96KG
	50KG / 100KG	51KG / 102KG	52KG / 104KG	53KG / 106KG
2KG BLOCK WEIGHT USE TOGETHER 1+2=3KG 	55KG / 110KG	56KG / 112G	57KG / 114KG	58KG / 116KG
	60KG / 120KG	61KG / 122G	62KG / 124KG	63KG / 126KG
	65KG / 130KG	66KG / 132G	67KG / 134KG	68KG / 136KG
	70KG / 140KG	71KG / 142KG	72KG / 144KG	73KG / 146KG
	75KG / 150KG	76KG / 152G	77KG / 154KG	78KG / 156KG
	80KG / 160G	81KG / 162G	82KG / 164KG	83KG / 166KG
	85KG / 170KG	86KG / 172G	87KG / 174KG	88KG / 176KG
	90KG / 180KG	91KG / 182G	92KG / 184KG	93KG / 186KG

Half rack addon Kit

Further expand the function of this machine with the addon kit and additional barbell to do free weights exercise



INCLUDED IN THE KIT ARE: (1) WEIGHT STORAGE SLEEVES, (2) SPRING COLLARS, (3) LANDMINE, (4) SPOTTER ARMS, (5) BARBELL STORAGE CATCH, (6) J-HOOKS



***BARBELL SOLD SEPARATELY (7)**





Option to use the back of the machine for half rack feature, which allows for 2 people to use the machine simultaneously

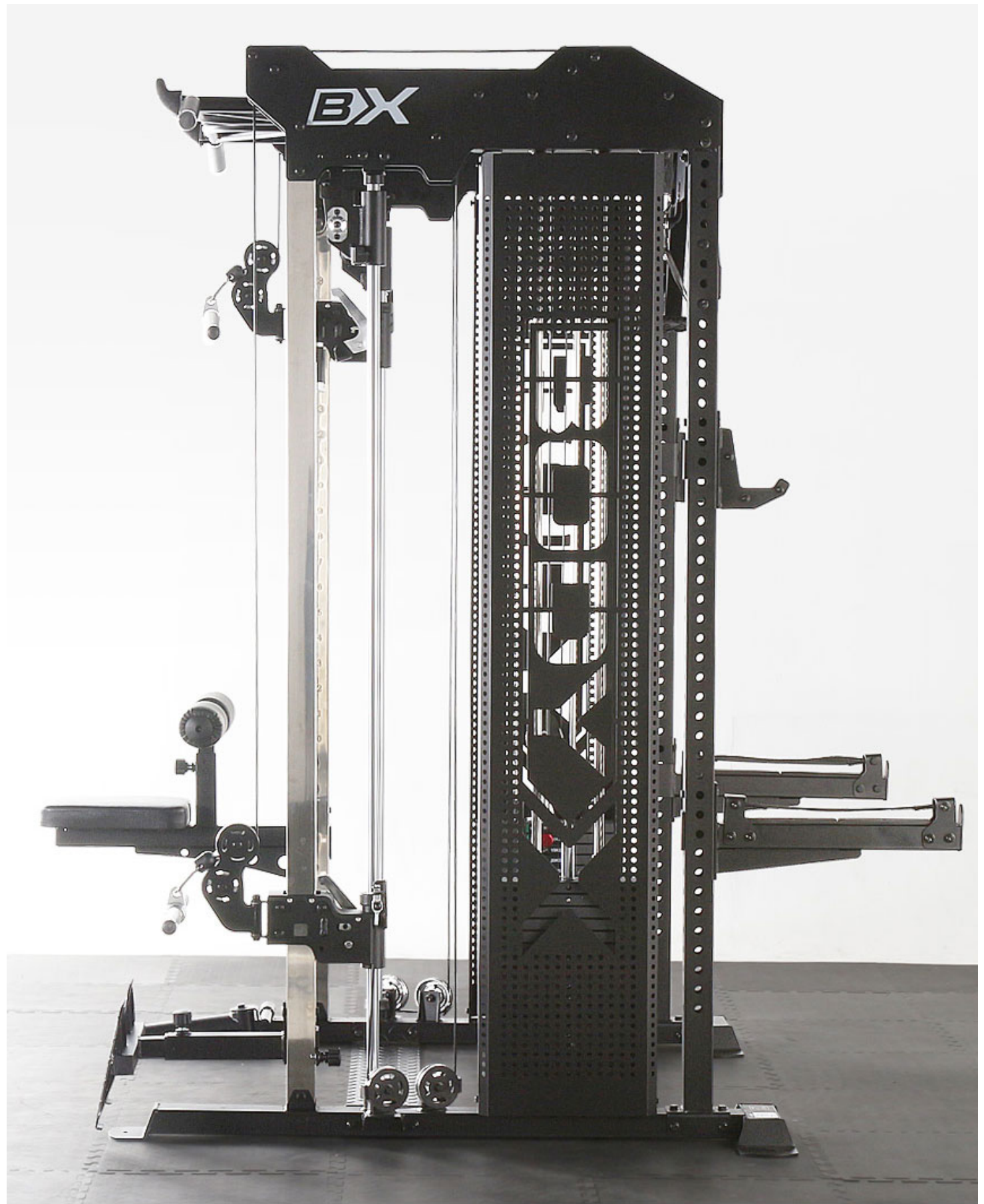



Dimension:

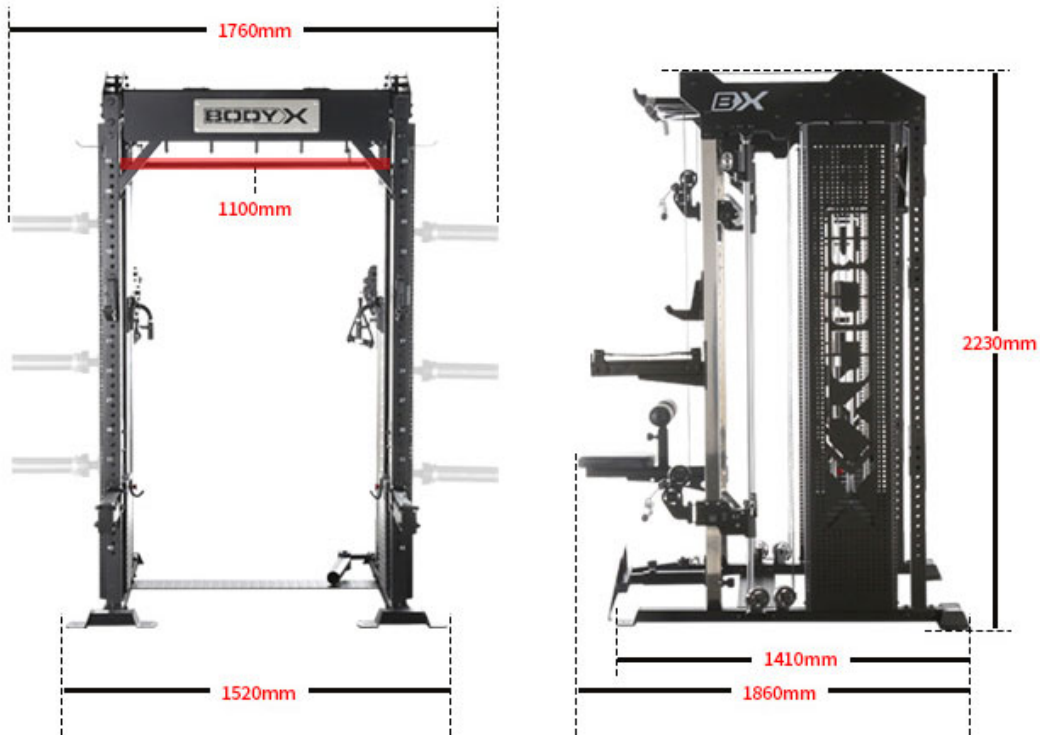

Features:

- Weight of Smith bar: 9.5kg
- Weight of Cable cartridges: 3.75kg
- Max Weight Limit: 300kg
- Upright specs: 60 x 60 x 2.5mm thickness

ADDITIONAL INFORMATION

More Information

Product Weight	400kg
Product Dimension	141 x 176 x 223cm (width x depth x height)
Max Load	300kg
Warranty	Mainframe: Lifetime, Other parts: 2 years, Labour: 1 year