



VIGOR BF900 PRO CONNECTED ALL IN 1 SYSTEM

SKU: V-BF900PRO





TRAIN BIGGER. USE LESS SPACE.

BF900 Pro – Maximum Functionality, Minimal Footprint

The **BF900 Pro** combines unmatched convenience with intelligent space-saving engineering, making it the ideal all-in-one strength training solution for modern homes and commercial facilities.

Its innovative **integrated weight stack connection system** allows users to train directly on the Smith Machine using the built-in weight stacks—eliminating the need for additional weight plates.

The result is a cleaner setup, quicker weight changes, and a more efficient training experience.

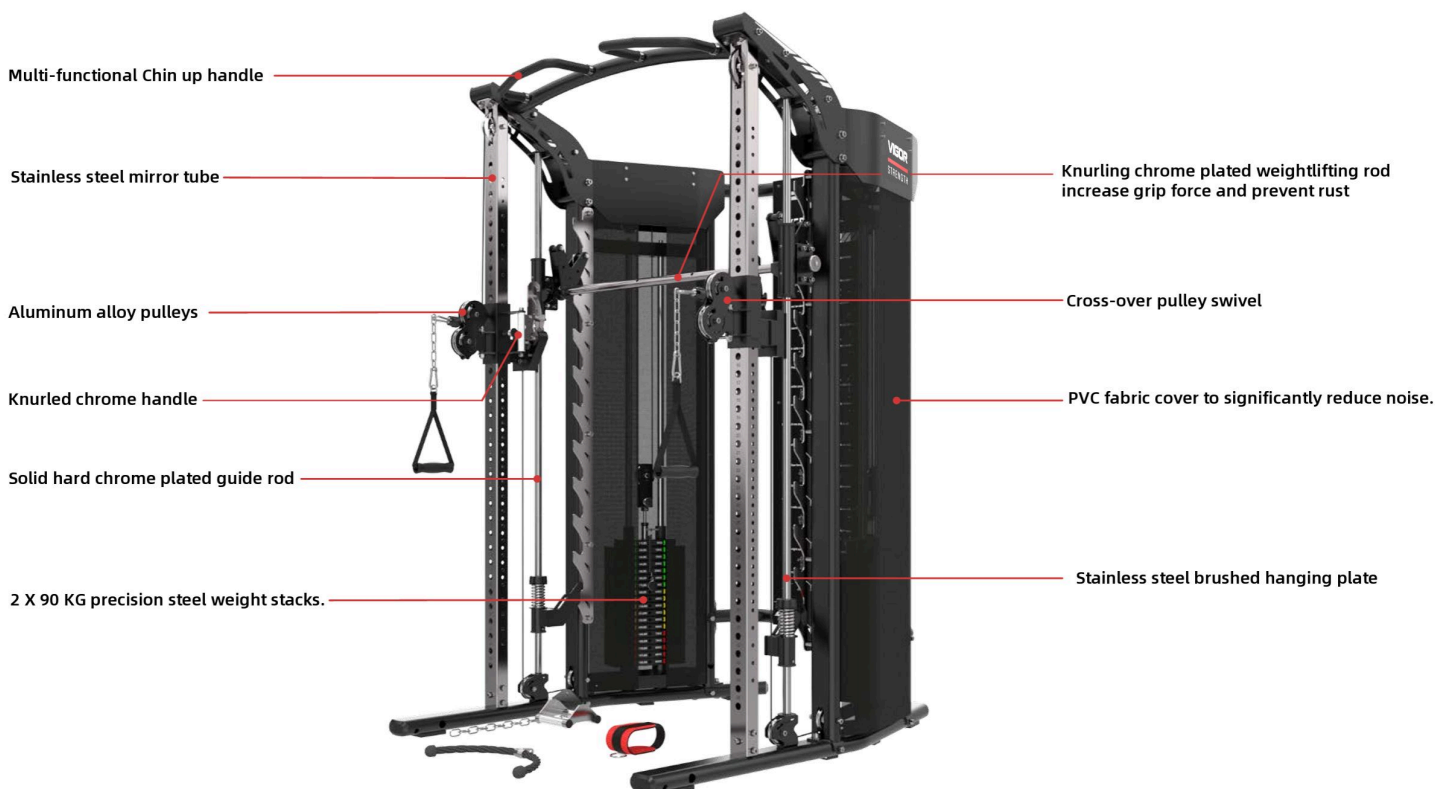

Save Up To 50% More Space

By eliminating the need for external weight plate loading, the BF900 Pro features a shortened Smith bar design that dramatically reduces the overall footprint without sacrificing functionality.

Traditional All-In-One Machine

2.8m × 2.0m

Average workout space required with side clearance and bench.

BF900 Pro

1.32m × 2.0m

Compact footprint with full Smith Machine functionality.

50% Less Width. 100% Training Capability.

CONNECTED WEIGHT STACK SYSTEM

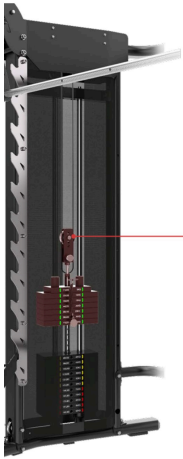

The unique cable system connects the smith machine bar directly to the weight stacks. There is no need to load and unload the barbell plate to change the training weight. Simply select the weight stacks with the pin and you are ready to train.

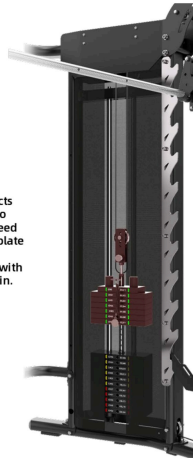

built-in weight stack, letting you harness the stack's resistance directly. With this innovative setup, you can train entirely with the **weight stack**. Enjoy a complete strength workout powered by the **built-in dual 90 kg weight stacks**, no extra plates required!

OPTIONAL SIDE SLEEVES

Lifting heavier weights? — the **Smith bar sleeves and weight storage** can be purchased and added separately. Load it up with **plates**, and **combine both** for a fully customized workout experience.

SmoothGlide Cable



A **high-quality cable system** runs throughout the machine, featuring **ultra-smooth aluminium pulleys** in the main mechanism. The result is a **seamless, fluid cable motion** that rivals the performance and feel of commercial-grade equipment.

WESTSIDE SPACING

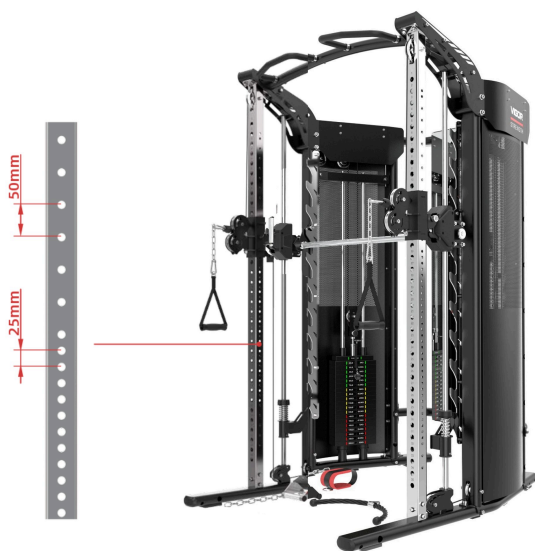

Crafted from **durable stainless steel front tubes**, the rack features **westside spacing** for enhanced accessibility and flexibility. The column holes are intelligently designed with **25 mm spacing near the bottom** for precise adjustments and **50 mm spacing through the middle and upper sections** to optimize positioning options. This innovative configuration allows **pulleys to be accurately positioned at the ideal height**, ensuring **smooth, synchronized operation** and maximum training versatility.

IMPACT RESISTANT MIRROR



Experience **crystal-clear reflections** with the included mirror, engineered from an **ultra-thin 0.04mm high-molecular polymer film** instead of traditional glass. Its innovative surface is **soft and resilient to the touch**, delivering a **uniquely smooth, elastic feel**. Completely **shatterproof** and highly **impact-resistant**, this advanced flexible design combines **exceptional clarity** with **outstanding durability** for everyday confidence.

MULTIPLE ATTACHMENT OPTIONS

What's included:

- Short Bar
- Lat Pulldown Bar
- Long Straight Bar
- Long Curl Bar
- Triangle Attachment
 - Ankle strap
 - Tricep Role
- Single PVC Stirrup Handles X 2
- Cable extension chains X 1

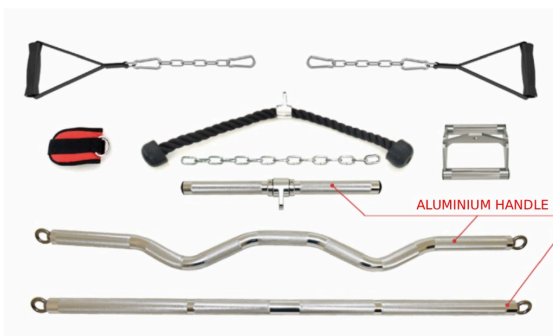

EASILY STORE YOUR ATTACHMENTS



The **BF900 Pro** features a cleverly integrated **hidden storage compartment** located behind the mirror, providing a convenient and organized space for all included attachments. Designed to keep your accessories **secure, easily accessible, and neatly stored**, this built-in storage system helps reduce clutter and ensures everything stays in one place when not in use.

The mirror can be **flipped open** to access the attachments directly from the front. The thoughtful design not only enhances everyday convenience but also maintains the BF900's **clean, streamlined appearance**, making it easy to keep your setup organized and ready whenever you need it.

Half Rack Addon

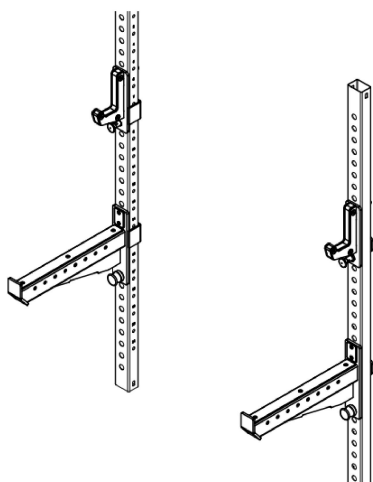

The **optional half rack** setup includes a pair of **J-hooks** and **Safety Spotters**, both designed to **lock securely** in place to prevent any swaying during use.

The J-hooks feature a **sturdy support backing**, making it easy to rack your bar smoothly and confidently. The **52.4 cm safety spotters**—longer than most on the market—provide generous support and security throughout your lifts.

Design Masterpiece



As more people embrace a **health-conscious lifestyle**, the role of a home gym has evolved beyond simply building physical strength. Today, it is about creating a sustainable environment that supports **daily wellness, movement, and healthy living**. With this vision in mind, we designed the **BF900 Pro** as more than just a piece of fitness equipment—it is a statement of modern living.

Thoughtfully crafted to fit seamlessly into most homes, the BF900 Pro combines **space-efficient functionality** with a refined aesthetic. Its elegant curves, clean lines, and carefully considered proportions allow it to integrate naturally into a variety of interior spaces, from bedrooms and living rooms to dedicated workout areas.

Featuring a premium combination of **soft curves, reflective mirror surfaces, and high-quality materials**, the BF900 Pro is designed to complement your home rather than disrupt it. The result is a fitness solution that looks as impressive as it performs, bringing together **style, organization, and functionality** in one sophisticated package.

Beautifully designed and exceptionally practical, the **BF900 Pro** transforms any space into a clean, inviting environment for exercise—making it easier than ever for everyone in the household to enjoy a neat, convenient, and effective workout experience.

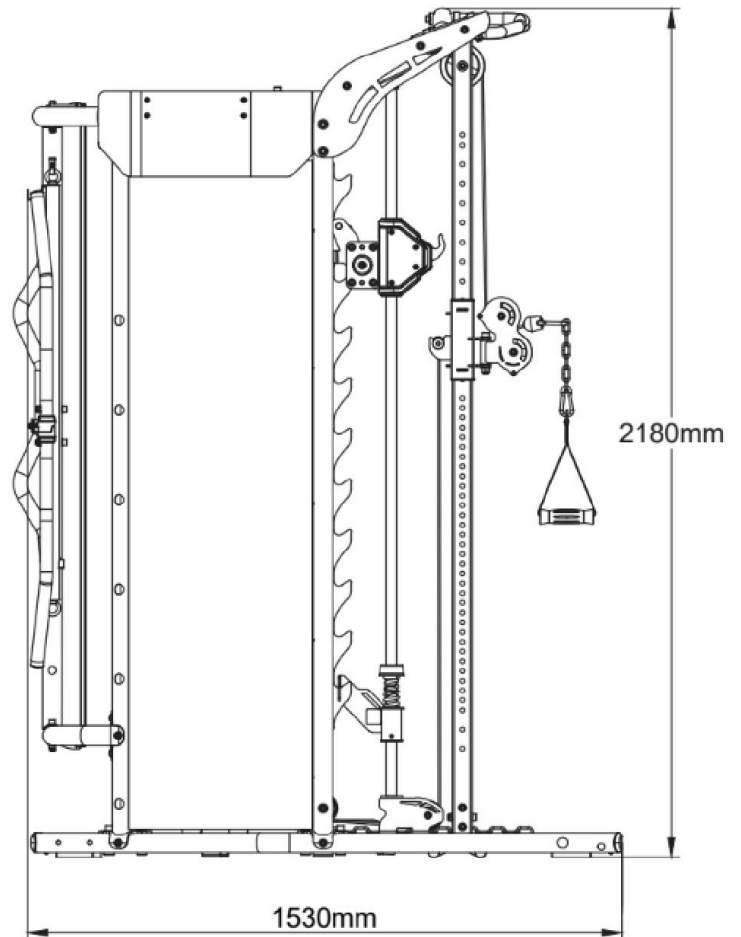
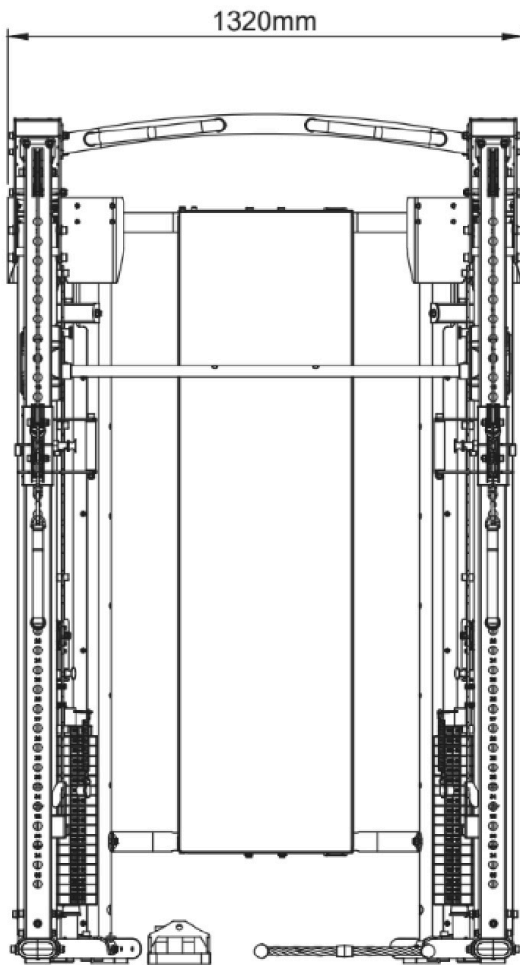

Tech Specs

- **Pulley Ratio** - 2:1
- **Half Rack Hole Adjustment** - 50mm Spacing.
- **Dual Cable Adjustment** - Westside Spacing 25mm at lower, 50mm at high.
- **Smith bar Hook Catch** - 120mm Spacing.

Max Load

- **Chin up Bar** - 158kg
- **Smith Bar** - 251kg
- **Half Rack** - 251kg



ADDITIONAL
INFORMATION

More Information

Product Weight	407kg
Product Dimension	153 x 132 x 218cm (L x W x H)
Warranty	1 Year