



BODYX BK3058 WITH 90KG WEIGHT STACK

SKU: VS-3058







PRODUCT
DESCRIPTION

The **Bodyx Counter Balance Smith Machine Functional Trainer Combo** has almost everything you need in free weight gym equipment. **The Bodyx** is one of a kind and the future of elite gym training. Never before has there been another piece of free weight gym equipment which can be used in as many ways as the **Bodyx** within the one piece of floor space.

ALL IN ONE GYM

- Half Rack
- Smith Machine
- Functional Trainer
 - Dip Station
 - Core Trainer
- Equipment Storage

KEY FEATURES:

- Thick steel barbell hooks with quick and easy height adjustment
 - Counter balance system for smith bar
- Chrome/stainless steel used for most contact points (more scratches-resistant)
 - Adjustable/Removable Dip Handles
- Thick steel barbell safety hooks with quick and easy height adjustment
 - Heavy duty cables and pulley
 - Extreme core trainer accessory
- Multi-grip chin up bar with comfortable knurling
 - Quick and easy pop pin functional adjustment
 - Thick steel support plates
- Ultra smooth smith machine movement and 30mm solid steel tubing
 - Weight plate storage
- Attachment accessories included such as straight bar, 2 x handle straps. Storage holding to keep your training space tidy.
 - Adjustable safety catches for Smith Machine exercises
 - Storage holder Olympic barbell
 - 1:1 Pulley Ratio
- Note: For local model, the exercise sticker provided will be different design

Accessories

- 2 x D handles
- Lat pulldown bar
 - Tricep rope
 - Barbell Pad
 - Straight bar
 - Dip handles
- Landmine + T bar handle
 - Low Row foot plate
 - J hooks
 - Safety arms
 - Knee holder



Counter Balanced Smith bar

Makes the starting weight of the bar 0kg.



MULTI-GRIP CHIN UP BAR





▼ MORE

FUNCTIONAL 듀얼 케이블

운동 가동범위 넓어지며
케이블은 당기는 힘과
미는힘이 2가지 이므로
운동 저항력이
훨씬 높아집니다

▼ MORE

SMITH 스미스

스미스바가 고정되어
정확한 자세를 잡아주며
부상방지 해결
안정성을 보장합니다



▼ MORE

HALF RACK 하프랙

운동 가동범위가 넓어
전신 근육 강화에
매우 좋습니다
운동의 다양성이
확보됩니다







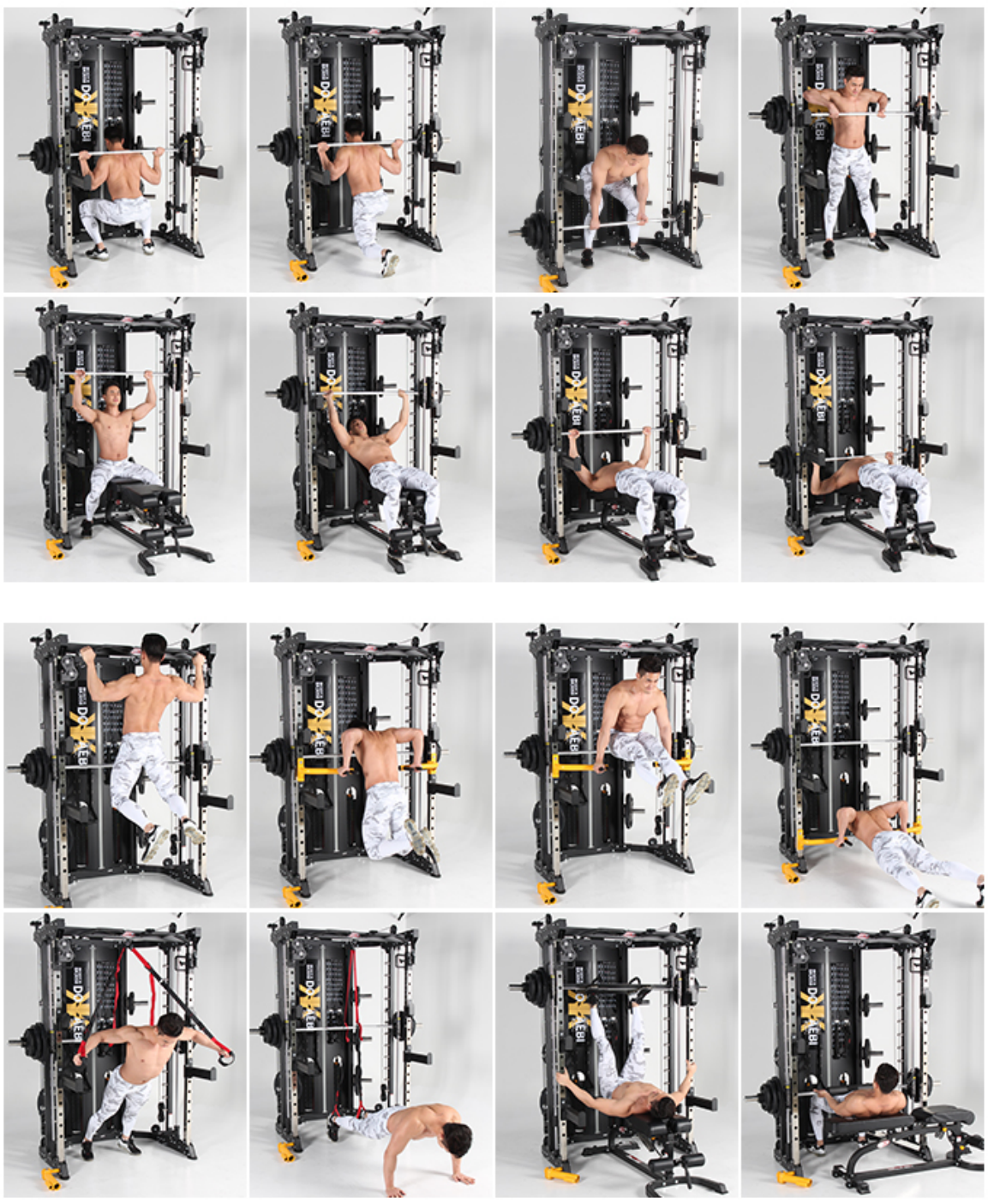

더 많은 운동방법은 매뉴얼을 참조하세요

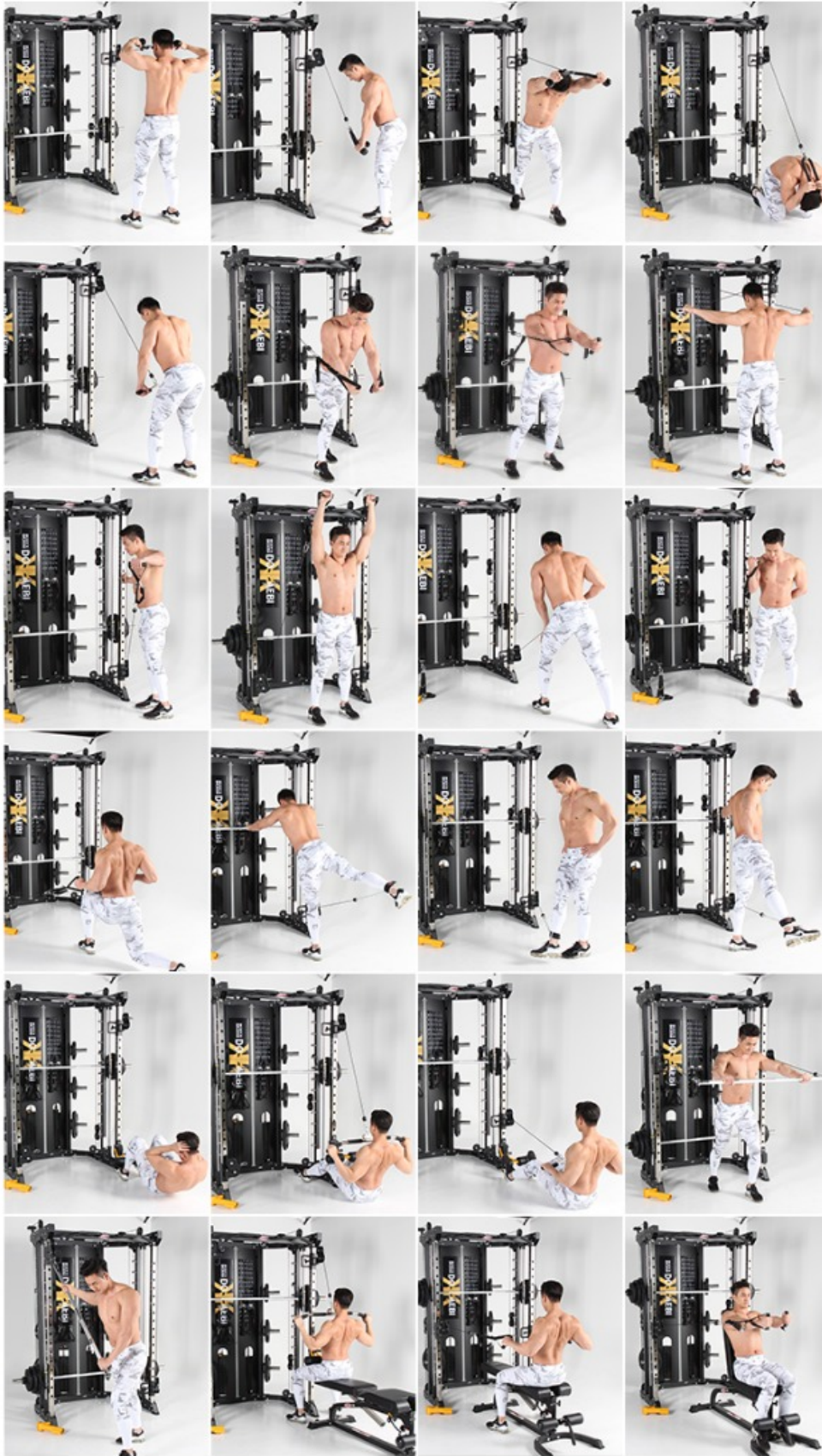

더 많은 운동방법은 매뉴얼을 참조하세요

ADDITIONAL
INFORMATION

More Information

Packaging	221 x 96 x 30 (369kg)
Warranty	Mainframe: Lifetime, Other parts: 2 years, Labour: 1 year
More Information	There will be slight colour variation from batch to batch. Please check with our staff to confirm.
Product Weight	373kg
Product Dimension	201 x 147.7 x 222.9 cm